

UNIVERSELLE GRIFFBÜGEL

- Schwenkbarer Tragegriff/Aufstellbügel aus Zink-Druckguss
- Dazu passendes Al-Profil in der passenden Breite Ihres Gehäuses als separates Verkaufsteil.

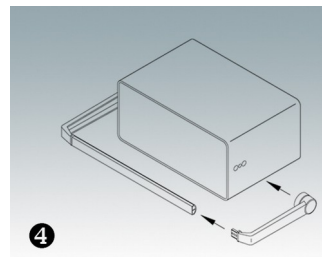

Versionen

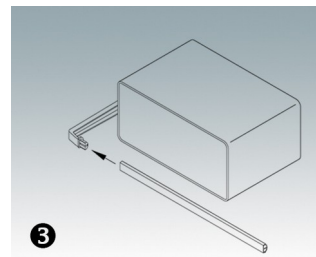
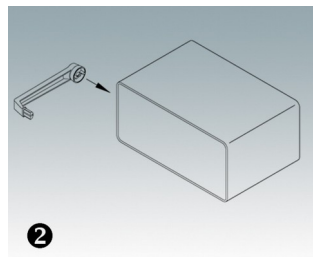
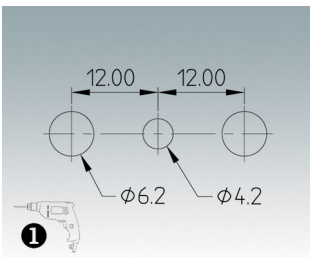
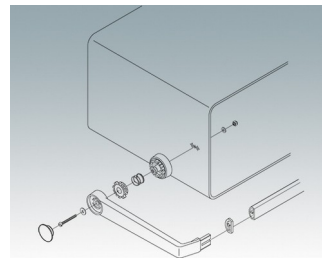
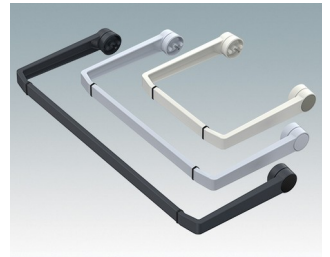
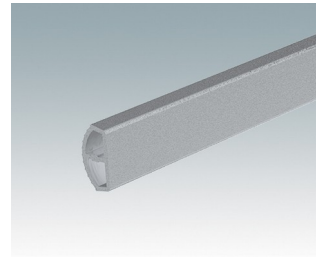
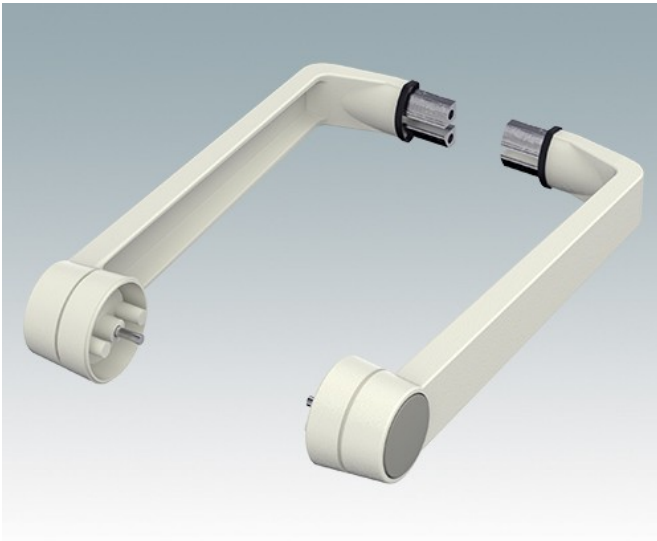
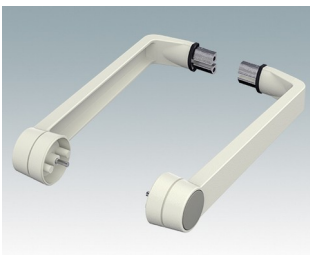

A9300014
Griffbügel Seitenteile
Zink
Grauweiß RAL 9002

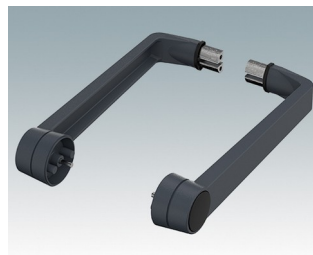

M5093004
Griffbügel Seitenteile
Zink
Anthrazit RAL 7016

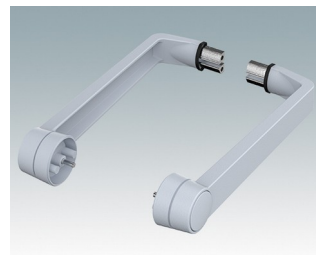

M5093005
Griffbügel Seitenteile
Zink
Lichtgrau RAL 7035



M5093009
Griffbügel Seitenteile
Zink
Schwarz RAL 9005

Systemkomponenten zum Komplettieren

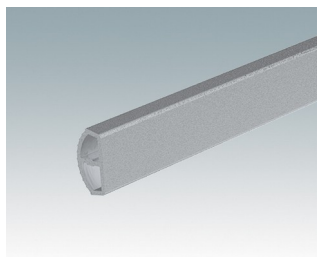

M50930-xxx
Griffprofil, RAL 9006
Aluminium
Weißaluminium RAL 9006

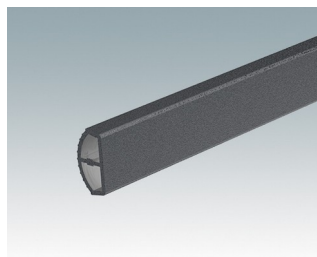

M50934-xxx
Griffprofil, RAL 7016
Aluminium
Anthrazit RAL 7016

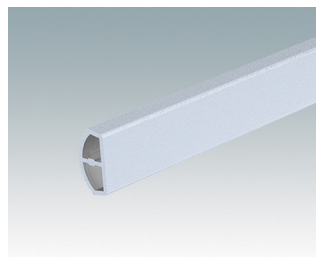

M50935-xxx
Griffprofil, RAL 7035
Aluminium
Lichtgrau RAL 7035

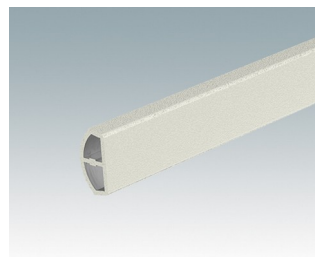

M50937-xxx
Griffprofil, RAL 9002
Aluminium
Grauweiß RAL 9002

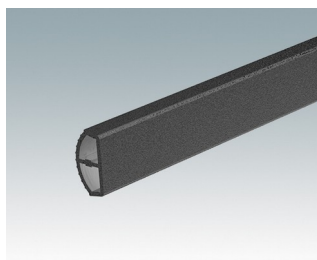

M50939-xxx
Griffprofil, RAL 9005
Aluminium
Schwarz RAL 9005

Technische Änderungen vorbehalten. © OKW Enclosures Ltd